

GAS TOOL PARTS LIST

GAS STRIP NAILER
Model GFN 3490

2008-4-1
(E1)

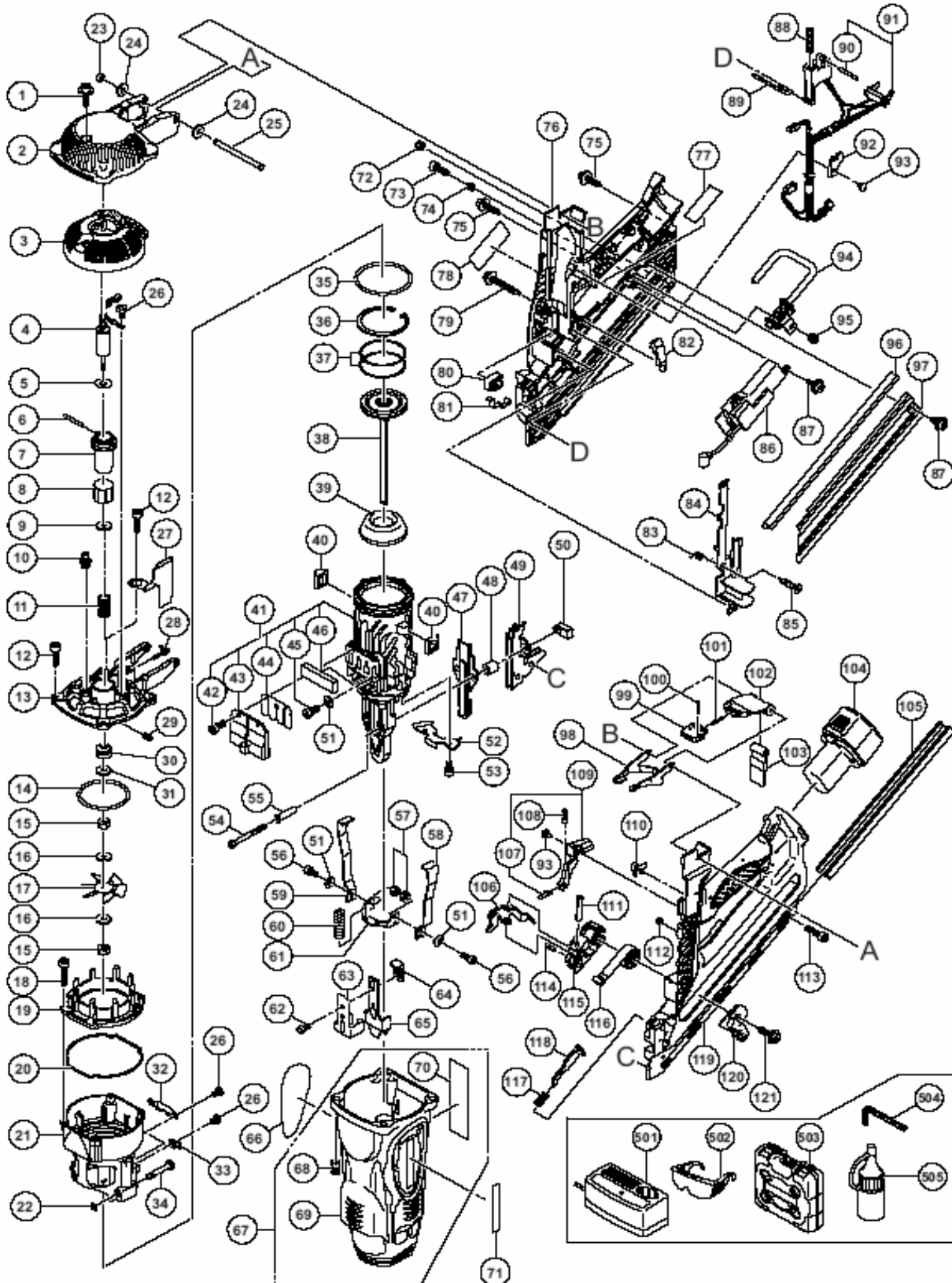

PARTS

GFN 3490

ITEM NO.	CODE NO.	DESCRIPTION	NO USED	REMARKS
1	996-399	HEX. SOCKET HD. BOLT (W/FLANGE) M5X12	1	
2	886-598	TOP COVER	1	
3	886-129	FILTER	1	
4	885-309	MOTOR	1	
5	885-313	RUBBER WASHER	1	
6	885-318	ROLL PIN D2.5X25	1	
7	885-310	MOTOR MOUNT	1	
8	885-314	MOUNT SLEEVE	1	
9	885-320	SHAFT WASHER	1	
10	885-333	SPARK PLUG (A)	1	
11	885-319	MOTOR SPRING	1	
12	949-757	HEX. SOCKET HD. BOLT M5X20 (10 PCS.)	4	
13	885-308	CYLINDER HEAD ASS'Y	1	INCLUD. 30, 31
14	885-316	O-RING (I.D 59. 92)	1	
15	949-554	NUT M4 (10 PCS.)	2	
16	949-423	WASHER M4 (10 PCS.)	2	
17	885-311	FAN	1	
18	949-754	HEX. SOCKET HD. BOLT M4X16 (10 PCS.)	4	
19	885-294	CHAMBER HEAD	1	
20	886-133	GASKET (B)	1	
21	885-296	CHAMBER	1	
22	878-607	PLUNGER O-RING	2	
23	880-319	SHAFT RING	1	
24	949-431	BOLT WASHER M5 (10 PCS.)	2	
25	885-277	SHAFT	1	
26	949-214	MACHINE SCREW M4X6 (10 PCS.)	4	
27	886-253	WIRING PLATE	1	
28	885-317	ADAPTER	1	
29	961-681	HEX. SOCKET SET SCREW M4X5	2	
30	886-470	SHAFT COVER	1	
31	886-471	WASHER	1	
32	885-297	CHAMBER LOCK PLATE	1	
33	885-306	SWITCH PLATE	1	
34	886-484	PIN (A)	2	
35	885-283	O-RING (I.D. 66. 27)	1	
36	885-285	RETAINING RING	1	
37	885-286	PISTON RING	2	
38	885-291	PISTON	1	
39	885-289	PISTON BUMPER	1	
40	885-284	CHAMBER STOP RUBBER	2	
41	885-361	CYLINDER ASS'Y	1	INCLUD. 42-46
42	949-812	HEX. SOCKET HD. BOLT M4X10 (10 PCS.)	2	
43	886-467	BUFFER COVER (A)	1	
44	885-290	LEAD VALVE	1	
45	303-631	SEAL LOCK SCREW M4X6 (BLACK)	2	
46	885-288	MUFFLER	1	
47	885-355	BLADE GUIDE	1	
48	885-270	PLATE SLEEVE	2	
49	885-326	SIDE PLATE	1	
50	886-544	SPECIAL NUT M5	2	

PARTS

GFN 3490

ITEM NO.	CODE NO.	DESCRIPTION	NO USED	REMARKS
51	886-242	BELLEVILLE SPRING M4	4	
52	885-299	CYLINDER PLATE	1	
53	980-046	SEAL LOCK HEX. SOCKET HD. BOLT M5X10	2	
54	886-545	NYLOCK HEX. SOCKET HD. BOLT M5X50	2	
55	885-269	NOSE SLEEVE	2	
56	886-241	SEAL LOCK HEX. SOCKET HD. BOLT M4X10	2	
57	956-329	U-NUT M4	2	
58	886-547	PUSHING LEVER ARM (D)	1	
59	886-546	PUSHING LEVER ARM (C)	1	
60	886-245	PUSHING LEVER SPRING (A)	2	
61	885-301	PUSHING LEVER CONNECTOR	1	
62	886-127	ADJUSTER BOLT	1	
63	886-128	PUSHING STOPPER	1	
64	885-272	ADJUSTER BUSH (A)	1	
65	886-144	PUSHING LEVER (A)	1	
66		NAME PLATE	1	
67	886-244	HOUSING ASS'Y	1	INCLUD. 68-70
68	885-304	SCREW M5	1	
69	886-134	HOUSING	1	
70	885-307	INSULATOR SHEET	1	
71		HEWI PLATE (H)	1	
72	876-465	NYLON NUT M4	1	
73	949-820	HEX. SOCKET HD. BOLT M5X15 (10 PCS.)	1	
74	878-164	SLEEVE	1	
75	302-086	TAPPING SCREW (W/FLANGE) D4X20 (BLACK)	5	
76	886-600	HANDLE (B)	1	
77		CAUTION LABEL	1	
78		WARNING LABEL	1	
79	301-815	TAPPING SCREW (W/FLANGE) D4X45	1	
80	885-334	SWITCH MOUNT	1	
81	885-347	SWITCH ARM	1	
82	885-338	PRISM (A)	1	
83	885-337	LOCK BAR SPRING	1	
84	885-339	WIRING COVER	1	
85	885-346	FLAT HD. TAPPING SCREW D4	1	
86	885-331	CONTROLLER	1	
87	309-933	TAPPING SCREW (W/FLANGE) D4X14 (BLACK)	3	
88	885-828	TRIGGER SPRING (A)	1	
89	885-340	CHAMBER LOCK BAR	1	
90	885-349	PIN D2.5	1	
91	885-798	TRIGGER INTERNAL WIRE (A) SET	1	
92	886-548	WIRING PLATE (B)	1	
93	885-714	TAPPING SCREW D3	2	
94	886-255	HOOK (B)	1	
95	877-371	NYLON NUT M5	1	
96	885-341	NAIL RAIL	1	
97	885-342	MAGAZINE PLATE	1	
98	886-141	CELL LEVER (A)	1	
99	885-280	LATCH	1	
100	949-859	ROLL PIN D2X8 (10 PCS.)	2	

PARTS

GFN 3490

ITEM NO.	CODE NO.	DESCRIPTION	NO. USED	REMARKS	
101	885-281	SPRING D3.6	1		
102	885-352	CELL COVER	1		
103	886-131	CELL RUBBER (A)	1		
104		BATTERY (GFN 3490B)	2		
105	885-354	MAGAZINE GUARD	1		
106	885-323	NAIL FEEDER (A)	1		
107	886-257	TENSION PLATE (C)	1		
108	885-518	SPRING	1		
109	886-147	SWITCH LEVER (B) ASS'Y	1	INCLUD. 107	
110	886-138	LEVER STOPPER	1		
111	949-506	ROLL PIN D4X28 (10 PCS.)	1		
112	886-543	SLEEVE	1		
113	880-003	HEX. SOCKET HD. BOLT M4X18	1		
114	883-687	SPRING	1		
115	885-324	NAIL FEEDER (B)	1		
116	885-325	RIBBON SPRING	1		
117	885-328	SPRING D8	1		
118	885-327	PUSHING LEVER STOPPER	1		
119	886-599	HANDLE (A)	1		
120	886-246	FEEDER KNOB	1		
121	302-089	TAPPING SCREW (W/FLANGE) D5X20 (BLACK)	1		

STANDARD ACCESSORIES

ITEM NO.	CODE NO.	DESCRIPTION	NO. USED	REMARKS	
501		CHARGER (MODEL GFN 3490L)	1		
502	875-769	SAFETY GLASSES	1		
503	886-601	CASE	1		
504	944-458	HEX. BAR WRENCH 4MM	1		
505	886-602	LUBRICANT OILER (B)	1		

OPTIONAL ACCESSORIES

ITEM NO.	CODE NO.	DESCRIPTION	NO. USED	REMARKS	
601	885-246	LUBRICANT OILER (A)	1		