

MBF 1850 HOBBY

EXPLODED VIEW DRAWING

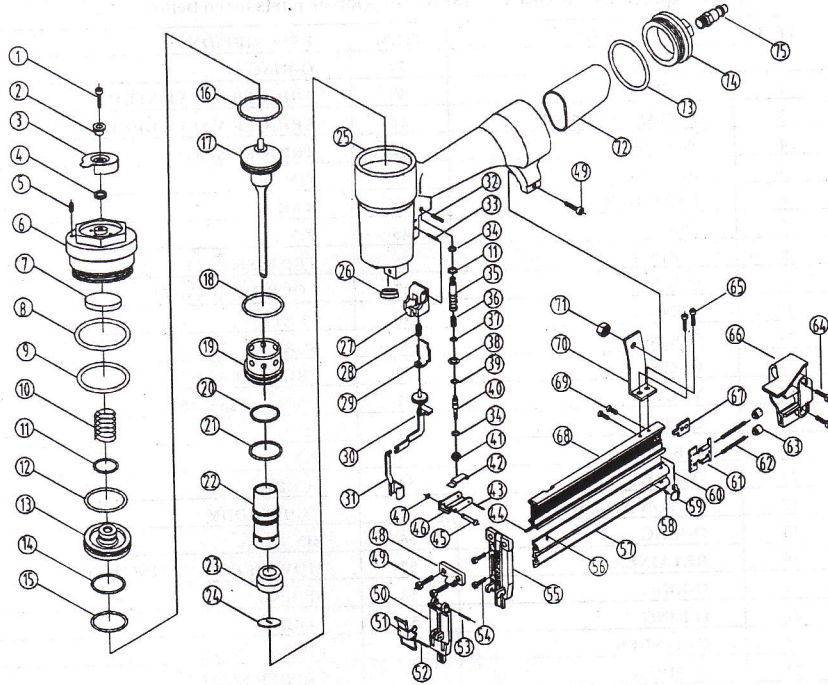

PARTS LIST

Refer to the Exploded View Drawing for the location of parts listed below

ITEM	DESCRIPTION	ITEM	DESCRIPTION
1	SCREW	39	O-RING
2	BUSHING	40	TRIGGER VALVE STEM
3	EXHAUST COVER	41	TRIGGER VALVE GUIDER
4	WASHER	42	TRIGGER SPRING
5	SCREW	43	PIN
6	CYLINDER CAP	44	RAIL
7	SEAL	45	PIN
8	O-RING	46	TRIGGER
9	O-RING	47	LOCKING WASHER
10	SPRING	48	PLATE
11	O-RING	49	SCREW
12	O-RING	50	FRONT PLATE
13	VALVE	51	LATCH ASSEMBLY
14	O-RING	52	PIN
15	O-RING	53	PIN
16	O-RING	54	SCREW
17	PISTON ASSEMBLY	55	GUIDE BODY
18	O-RING	56	PIN
19	RETAINER	57	MOVABLE MAGAZING UNIT
20	O-RING	58	SPRING
21	O-RING	59	LOCK
22	CYLINDER	60	PIN
23	BUMPER	61	FEEDER SHOE
24	JOINT GUIDER	62	SPRING
25	BODY	63	SPRING RETAINER
26	WASHER	64	SCREW
27	SAFE GUIDER	65	SCREW
28	SPRING	66	STOPPED PLATE
29	SAFE BRACKET A	67	STOPPED
30	SAFE BRACKET B	68	FIXED MAGAZINE UNIT
31	SAFE BRACKET C	69	SCREW
32	SCREW	70	SUPPORT
33	PIN	71	NUT
34	O-RING	72	SOFT GRIP SLEEVE
35	TRIGGER VALVE HEAD	73	O-RING
36	SPRING	74	END CAP
37	O-RING	75	AIR PLUG
38	O-RING	76	